

# ***DOMINATOR***<sup>TM</sup>

**Models 2098 and 2198**

**Dome and Super-Silo Systems**

The ***NEXT GENERATION*** of ***HIGH-VOLUME*** vertical storage  
and automated ***HIGH-DELIVERY*** reclaim.

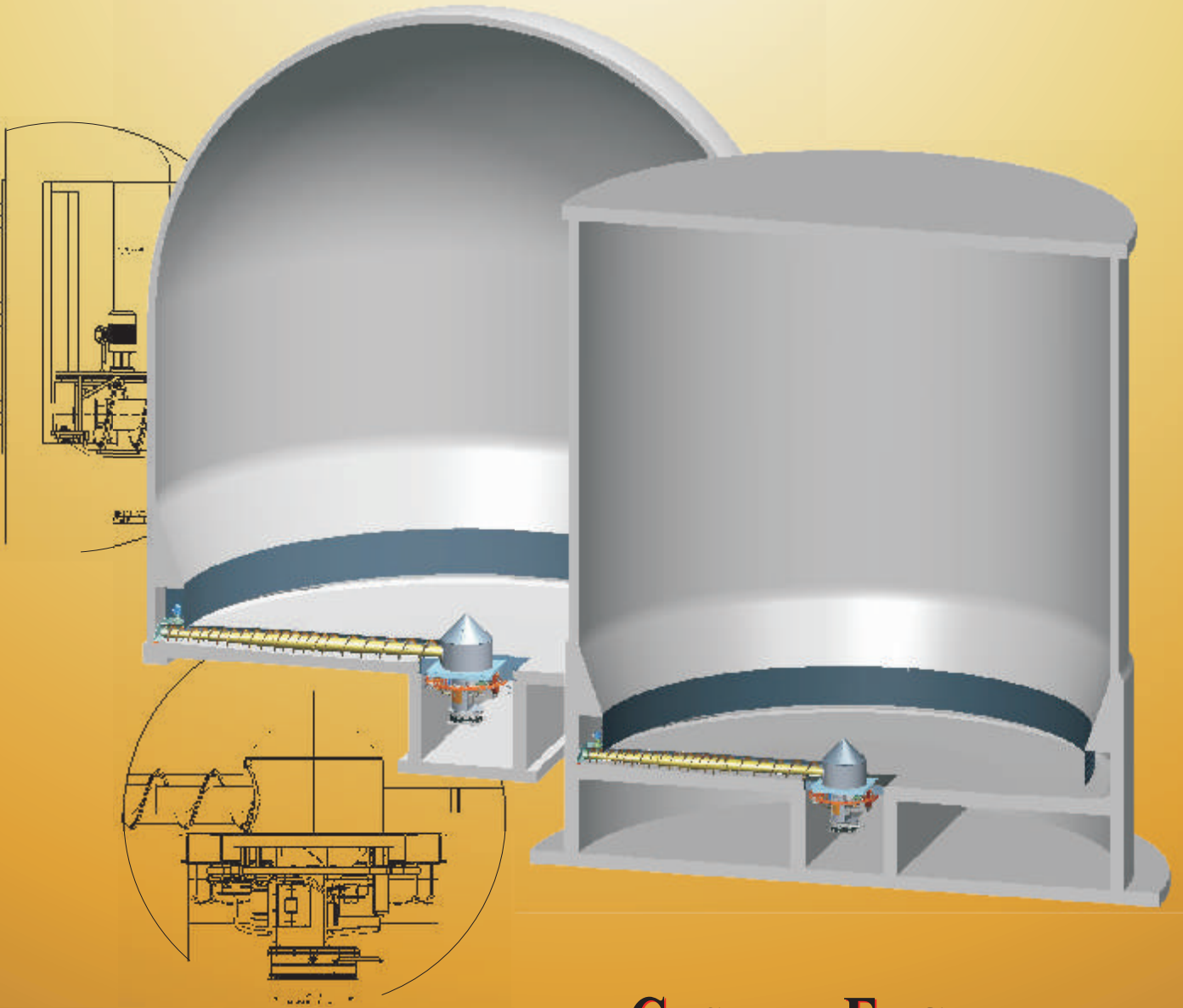

**CUSTOM ENGINEERED  
FOR  
EXTREME CHALLENGES**



**Bulk Storage and Reclaim Systems**

## ENGINEERED FOR THE FUTURE...

**DOMINATOR™** integrates state-of-the-art vertical storage technology with the latest innovations in track-driven reclaim design to set a new standard for high-volume storage and reclaim systems.

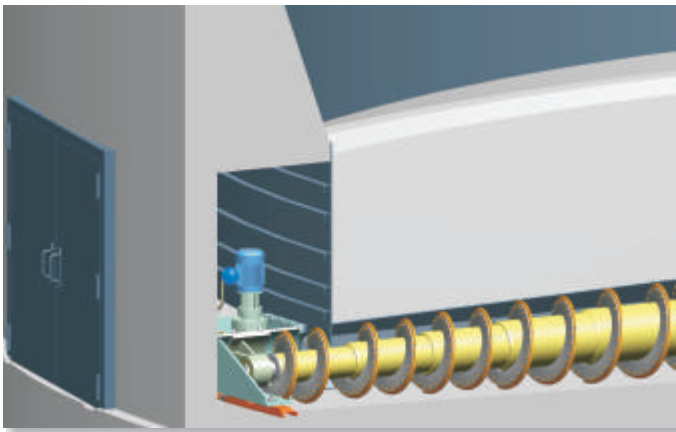

The track-driven advance is located in the Perimeter Access Area.

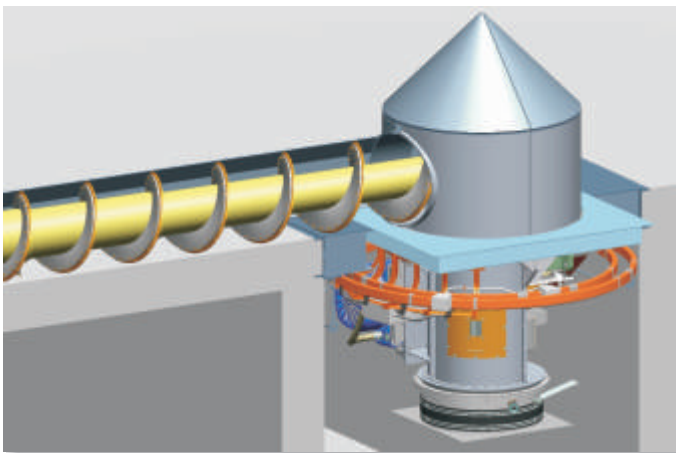

Reclaimed material is conveyed via the discharge chute in the Central Access Tunnel.

Get high speed, continuous load-out to trucks, railcars or ships.

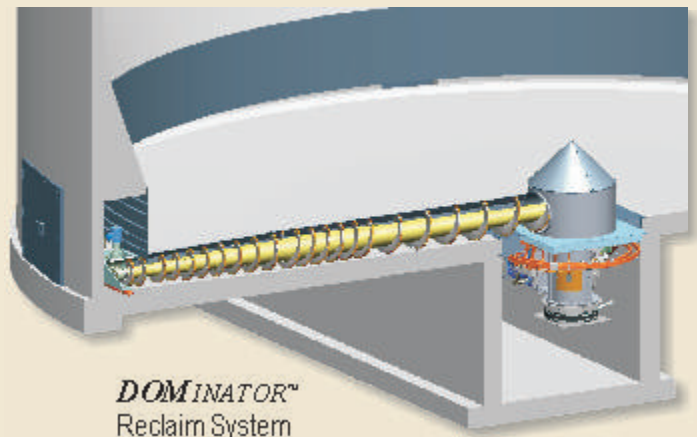

**High-Volume, High Delivery** - Efficient volume utilization of dome structures allows up to 800,000 CF (22,700m<sup>3</sup>) usable storage with continuous delivery rates as high as 600 CFM (17m<sup>3</sup>/min).

**Material on Demand** - Push-button control delivers the material you want when you want it.

**Inventory Control** - Approach first-in-first-out (FIFO) inventory control by reclaiming oldest material first.

**Consistent Delivery** - Uninterrupted high-volume discharge allows easy integration with continuous-process applications.

**Improved Performance** - Eliminate irregular discharge, multiple draw downs, and other disadvantages associated with top-reclaim systems.

**Simultaneous Loading and Reclaiming** - Loading from the top while reclaiming from the bottom saves time and increases process efficiency.

**Reduce Labor Costs** - Automated reclaim technology eliminates the need for dedicated personnel to manually unload material.

**Improved Safety** - Reduce confined-space concerns by locating drive systems and serviceable components outside the material storage area.

**Environment-Friendly Processing** - Loading and reclaiming in a closed structure enables control of particle emission.

## ...PROVIDING ADDED VALUE TODAY

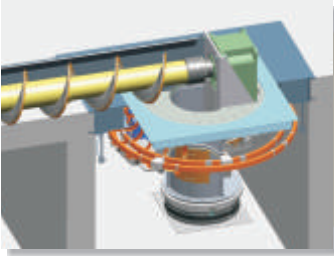

**Massive Reclaim Auger** - A large-diameter reclaim auger (up to 36" or 92cm) is powered by Laidig's energy-efficient reclaim drive system (200 HP max or 149kW). The rugged auger shield provides highly efficient material conveyance.

**Rugged Center Bullring** - Reclaim auger, shield, and gearmotor are mounted on a rugged, large-diameter, rotating bullring to provide rigid support.



**High-Efficiency Cutting Blades** - Austempered ductile-iron cutting blades provide high efficiency reclaiming, reduced starting-torque, and minimal reclaim advance resistance.

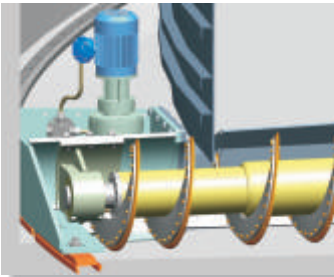

**Variable-Speed Track-Driven Advance** - Laidig's unique self-cleaning track-driven reclaim advance ensures dependable variable-speed advance.

**Easy-Access Perimeter Service Area** - The Perimeter Access Area allows easy service of the advance drive system, and is protected with a reinforced high-strength steel shield fully integrated with the storage structure.

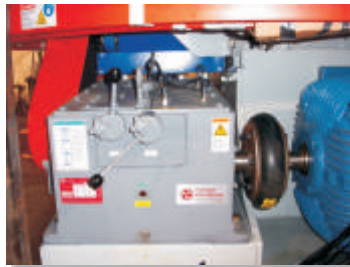

**Multi-Speed Reclaim Rate** - A heavy-duty four-speed gearbox delivers ultra-high torque at low reclaim speeds for reliable start-up under heavy loads. A 3:1 transmission ratio allows faster reclaiming when high discharge rates are required.

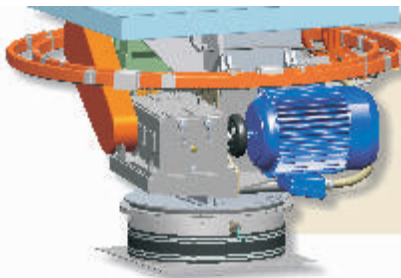

**Enclosed Conductor Bar System** - Electrical power for the reclaimer is transmitted to the rotating chute and reclaim drive systems via the fixed enclosed conductor bars.

**Discharge Options** - Discharge augers and conveyor systems can be provided by Laidig to assure steady and reliable flow to the customers' fill points. Customized adapters can also be provided for integration with the existing discharge system.



**Customized Control System** - A PLC-controlled Local Control Station (LCS) is custom-designed for full integration with the customer's Main Control Station. Optionally, Laidig can provide the Main Control Station.

40 YEARS OF PIONEERING LEADERSHIP IN TRACK-DRIVEN RECLAIM SYSTEMS

# WHEN PERFORMANCE IS CRUCIAL, DEPEND ON LAIDIG.

## WE DELIVER... GUARANTEED.



Each reclaim system is pre-assembled and power-tested prior to installation.



**Dome Storage Capacity**  
100' (30m) Material Height; Single Fill Point

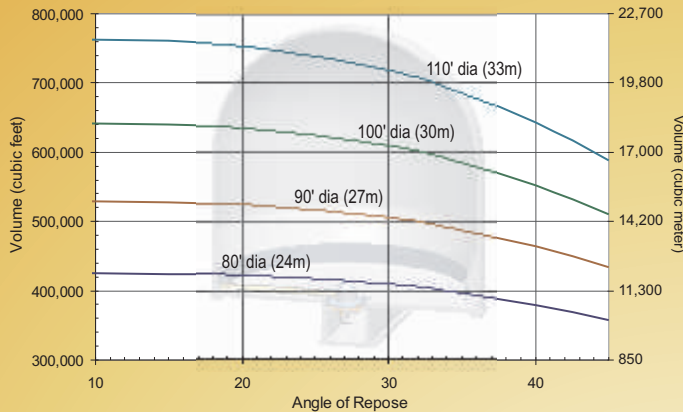

**Super-Silo Storage Capacity**  
100' (30m) Material Height, Single Point Fill

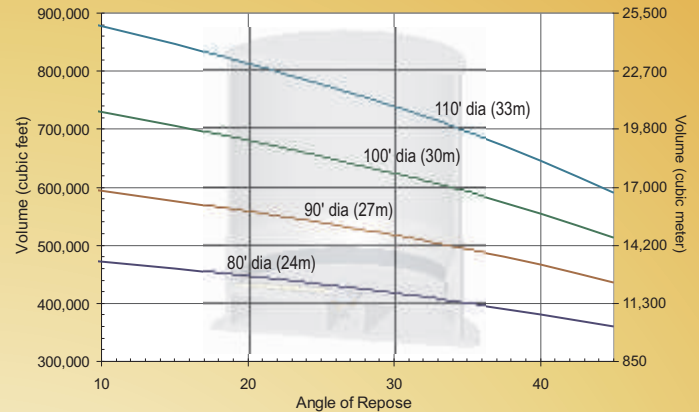

### WITH LAIDIG YOU GET THE TOTAL PACKAGE:

#### The Storage Structure

Designed specifically for the dynamic-load requirements of bottom-reclaim systems.

#### The Reclaim System

Custom engineered for high delivery rates with a wide range of material applications.

#### The Laidig Guarantee

If we design and install your storage and reclaim system, we guarantee it will work.

**WE DON'T JUST SELL EQUIPMENT, WE PROVIDE SOLUTIONS.**

Specifications*	Model 2098	Model 2198
<b>Silo/Dome Diameter</b>	110' (33m) max	110' (33m) max
<b>Drive System</b>	150 HP (112kW) max	200 HP (149kW) max
<b>Cutting Diameter</b>	32" (83cm) max	36" (92cm) max
<b>Nominal Delivery</b>	~400 CFM (11m <sup>3</sup> /min)*	~600 CFM (17m <sup>3</sup> /min)*
<b>Discharge Opening</b>	5.7 ft <sup>2</sup> (.53m <sup>2</sup> )	5.7 ft <sup>2</sup> (.53m <sup>2</sup> )
Slide Gates or Discharge Augers available for both models.		

\* Nominal specifications are shown. Consult a Laidig applications engineer for material-specific information.

\* Delivery rate is dependent upon material flow characteristics.



### Laidig Systems, Inc.

14535 Dragoon Trail  
Mishawaka, IN 46544 USA

Phone: 574-256-0204

Fax: 574-256-5575

sales@laidig.com

www.laidig.com

Copyright © 2008 rev e

Laidig Systems, Inc.