

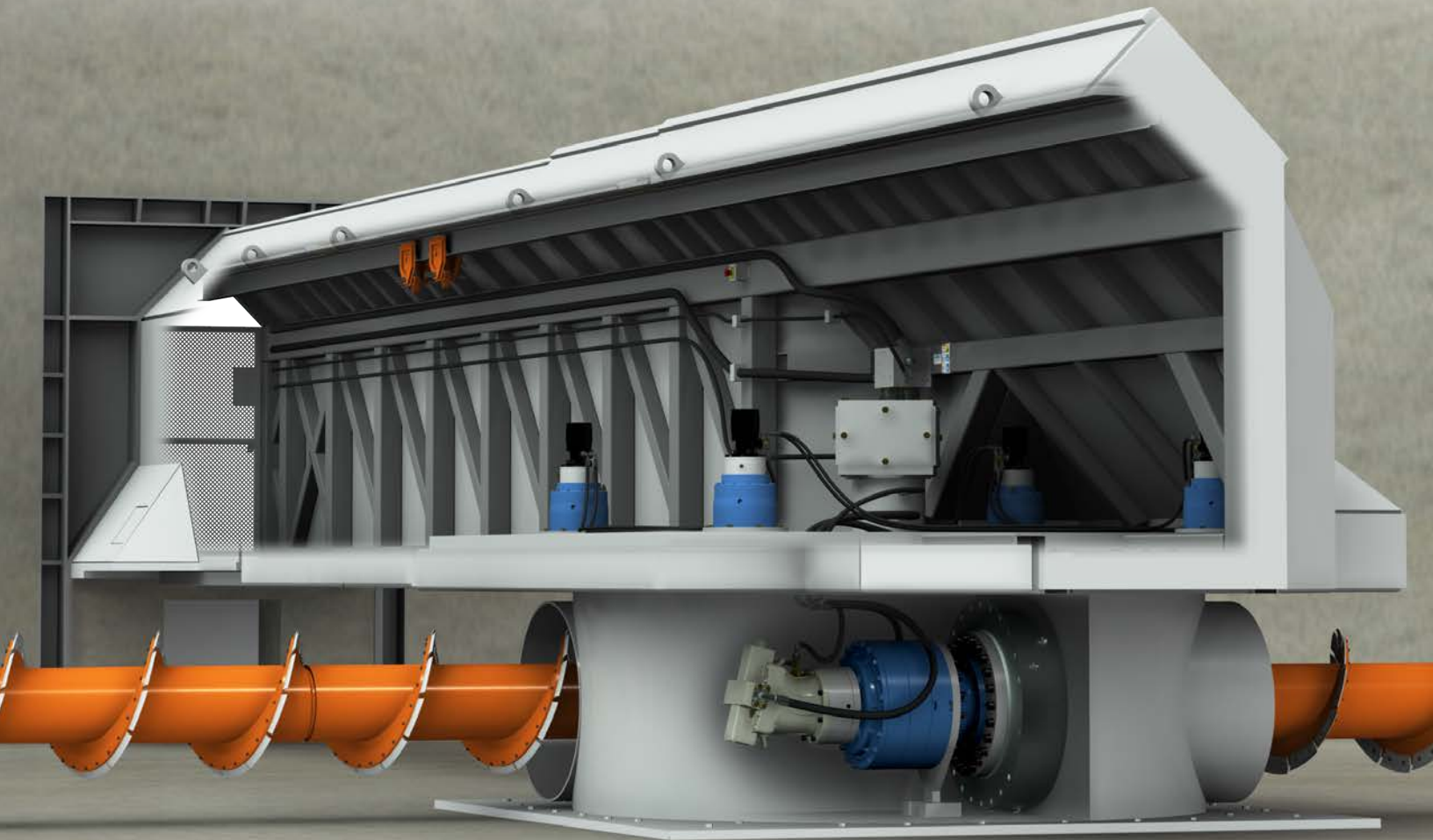

**Bulk Storage and  
Automated Reclaiming  
Solutions**

# **SYMMETRIX™**

**Model SM933**



**HIGH-VOLUME STORAGE AND RECLAIM OF HIGH-DENSITY OR ABRASIVE MATERIALS**

## FULL SILO TOTAL ACCESS

Laidig **Symetrix** reclaimers offer superior performance and dependability for applications with high-density or abrasive materials. Laidig's **Symetrix** system is engineered to provide completely automated, near-total clean out, encouraging first-in-first-out (FIFO) material distribution for processing to strict quality-control standards.

The **Symetrix** provides an access beam which spans the radius of the storage vessel. This beam offers complete access to all components of the **Symetrix**, even under a full head-height of material. Serviceable components include motors, gearboxes, reducers, and the auger cutter blades. Even the entire auger can be removed from a full silo through the auger access door at the end of the beam.

Since the access beam bears the material load and shields the auger from high compressive forces during both the fill and subsequent operation, the **Symetrix** is the system of choice for high-density materials. Coal, dense powders, and heavy or coarse granular materials are ideal applications for the **Symetrix**.

## ABRASION RESISTANCE

Consistent exposure to rugged and abrasive materials can lead to premature wear and the reduction in the life expectancy of critical equipment components.

Laidig has done extensive research and development to provide the very best abrasion resistance options specifically to ensure your equipment will hold up even in the harshest of conditions. These Laidig options include: hardened flight, carburized auger knives and blades, and a total hard-facing of the auger flighting and tube.

## RUGGED DESIGN

Laidig's **Symetrix** reclaim system is designed for durability and longevity. Hydraulic advance components are utilized to provide ultimate control sensitivity of the **Symetrix**, increasing running efficiencies and reducing wear on the auger and drive components. All conveying surfaces have been optimized to accommodate highly-abrasive materials, greatly reducing wear. The tapered auger design, together with the load bearing access beam make the **Symetrix** ideal for dense, heavy materials.

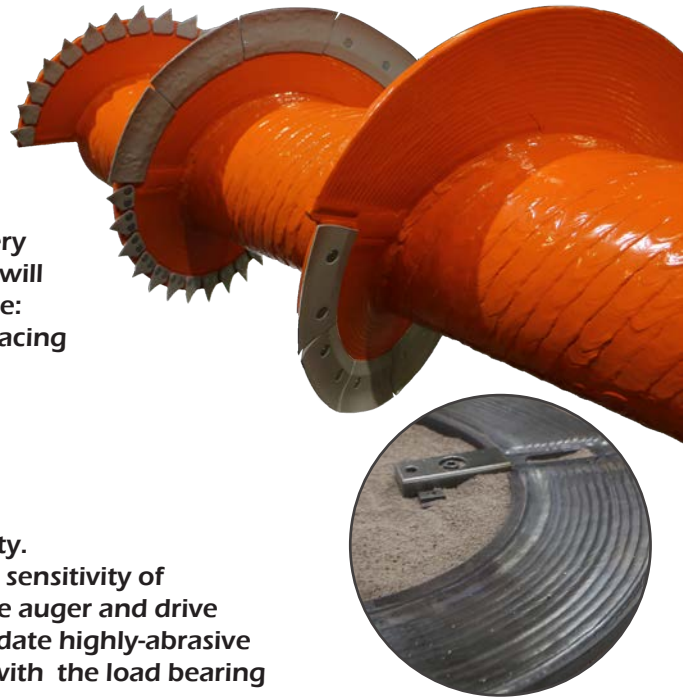

## LAIDIG MACHINE INTERFACE

The Laidig **Symetrix** offers intelligent, fully-automated, push-button operation utilizing Laidig's LMI™ (Laidig Machine Interface). The LMI provides the operator with maximum control and flexibility while ensuring the reclaimer is running in a safe and efficient manner. It allows full control and monitoring of the reclaimer's status and operation in a graphic-rich display. The LMI provides an interface to safely control the **Symetrix** reclaim system, which can be integrated with various types of customer control systems. It can also include remote access capability for monitoring or troubleshooting the system off-site.

\*All Laidig LMI's are custom engineered to each reclaim system. UL has tested representative samples and determined they meet the specific, defined requirements based on UL's published and nationally recognized standards for safety.

# SYMETRIX FEATURES

- State-of-the-art engineering to meet the toughest material challenges
- Total access to reclaim equipment, even in a full silo
- Engineered for heavy-duty, rugged applications – 24/7
- Fully-automated, dependable, push-button operation
- Promotes First-In-First-Out (FIFO) material management
- Diameters up to 110 ft (34 m) with half-diameter access beam
- Free access to Laidig's lifetime technical support

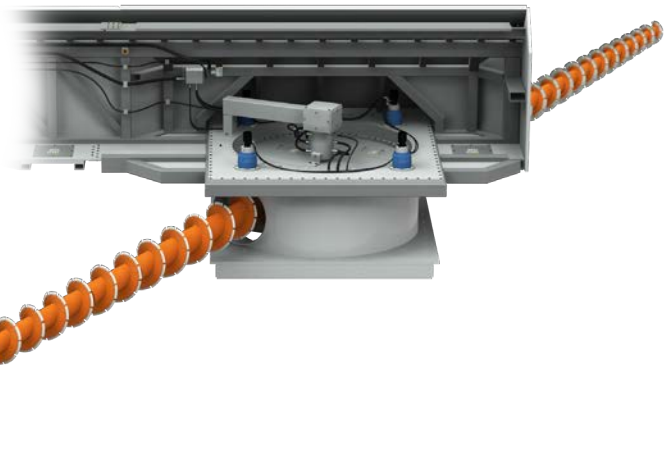

## PERSONNEL ACCESS

Reclaim drive components can be accessed and replaced via the beam, even if in a full silo.

## ACCESS BEAM

The access beam shields reclaim components in dense materials, allowing them to operate smoothly and efficiently. In addition, the beam enables the entry for inspection of all equipment.

## AUGER INSPECTION

Access openings in the beam floor allow the reclaim auger and the hardened cutter blades to be inspected and replaced without emptying the silo.

## TROLLEY SYSTEM

The trolley assists the installation or removal of motors, reducers and gearboxes from inside the beam.

## TAPERED AUGER

A state-of-the-art fully-tapered auger with continuously variable-pitch flighting is designed to require the lowest-possible starting torque and advance pressure. The auger is fit with hardened, replaceable cutters, bolted to abrasion-resistant flighting and auger tube.

## DEFLECTOR SHIELD

The center deflector is designed to prevent free-flow, allowing the delivery rate to be controlled entirely by auger rotation. In many cases this eliminates the need for an additional metering device.

## AUGER REMOVAL

The auger may be removed through the access door without emptying the silo.

## DRIVE SYSTEM

The drive system is fully hydraulic with drive components fully accessible and protected from material contamination.

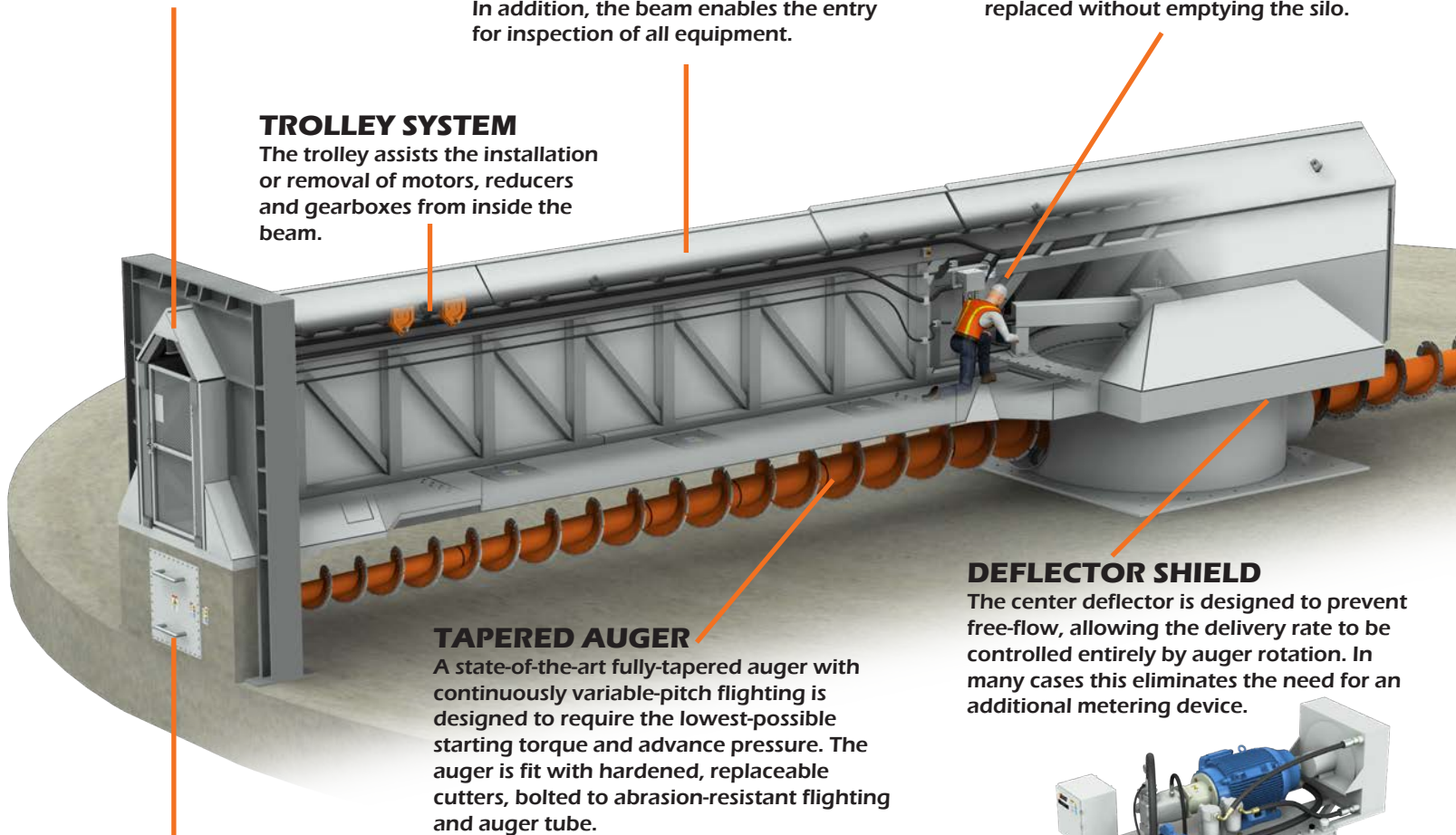
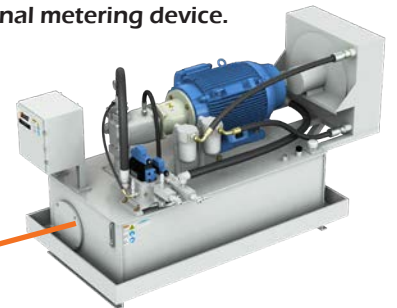

# HEAVY-DUTY STORAGE AND RECLAIM SOLUTIONS FOR TOTAL ACCESS EVEN IN A FULL SILO!



Laidig's **Symetrix** reclaim systems are designed specifically for heavy-duty, industrial applications requiring reclamation of high-density, abrasive materials with poor flow characteristics or other properties which make them difficult to handle. Laidig's turnkey installations typically include concrete silos or monolithic domes.

## Laidig Symetrix Specifications

Specifications*	Model SM933 All Hydraulic
Storage Diameter	110' (34 m)
Auger Cutting Diameter	32" (81.3 cm)
Auger Capacity	610 cfm (17.3 m <sup>3</sup> /min)
Auger Rotation	30 RPM
Discharge Opening	12 ft <sup>2</sup> (1.11m <sup>2</sup> )
Hydraulic Power Unit	200 HP

\* Data shown conveys generalized specifications of the referenced Laidig reclaimers. Material characteristics and other application-specific parameters can significantly alter reclaim specifications. Please contact a Laidig technical sales representative regarding capabilities for specific applications.



## With Laidig, You Get More Than Steel...

- Custom Engineering and Design
- In-House Manufacturing
- Construction Services and Support
- Customer Service

**If we design and install your storage and reclaim system, we guarantee it will work.**

### ADDITIONAL OPTIONS:

- Automatic Variable-Speed Drives
- Discharge Conveyor Systems
- Hydraulic Fluid Immersion Heater
- Ultra-Wear AR Design
- Stainless Steel Fabrication
- Hazardous-Environment Design



**Laidig Systems, Inc.**

14535 Dagoon Trail  
Mishawaka, IN 46544

574.256.0204

sales@laidig.com

 youtube.com/LaidigSystems

© Laidig Systems, Inc. 8/22 Rev E